

Student's Introduction to the HP8714 RF Network Analyzer

Prepared by Mike Eberly and Larry Dunleavy

INTRODUCTION

A vector network analyzer, or VNA, is an instrument which measures the complex transmission and reflection characteristics of two-port devices in the frequency domain. It does this by sampling the incident signal, separating the transmitted and reflected waves, and then performing ratios that are directly related to the reflection and transmission coefficients of the two-port. Frequency is swept to rapidly obtain amplitude and phase information over a band of frequencies of interest.

The s-parameter representation is the most common format used to represent VNA measurements. The s-parameters S11 and S21 can be interpreted as the input reflection coefficient and forward transfer coefficient (gain or loss) under the conditions that the source and load impedances represent perfect Z_0 (e.g. 50W) conditions. Likewise S22 and S12 can be interpreted as the output reflection coefficient and reverse transfer coefficient (gain or loss) under the conditions that the source and load impedances represent perfect Z_0 (e.g. 50W) conditions. User calibration is necessary to correct for cable losses, to correct for non- Z_0 conditions, and to establish phase reference planes.

The HP 8714 VNA is a one-path two-port measuring instrument that covers a frequency range of 0.3MHz to 3000MHz. This translates into a direct convenient measurement of S11 and S21 of a device, and the need to physically reverse the device to measure S12 and S22. This is in contrast to a full S-parameter capability, available for example on the HP8510, HP8753, and Wiltron 360 network analyzers, which measure all four S-parameters with a single connection. Consequently the HP8714 is a relatively low cost RF VNA solution that turns out to be very easy to use and very powerful in its overall capabilities. In addition to its use as a VNA to measure S-parameters, the HP8714 can also be used as a power meter as well as a scalar detector, features which are very useful for certain specialized measurements.

The operation of the HP8714 is menu based, The highest level of this menu can be considered the front panel of the HP8714. If you compare the outline to the front panel you will see this. Note that the "Begin" and "Preset" Keys are mentioned individually. These keys, if used properly can save time from having to configure the machine "manually". The selections which appear in the outline but don't appear on the front of the machine are implemented using soft keys. A familiar concept to users of HP equipment(such as calculators), as they seem to have adopted the idea for everything.

This tutorial will tour of the functions of the HP8714. This should give you a quick reference to locate the functions at a glance. Feel free to verify the outline by exploring the menus. In the outline short notes to describe the functions will be given along with a page reference to the pages in the user's guide which will give you more information on the function or functions which fall below that particular menu option. After the menu "tour", procedures are summarized for reflection, transmission, and normalization types of calibration.

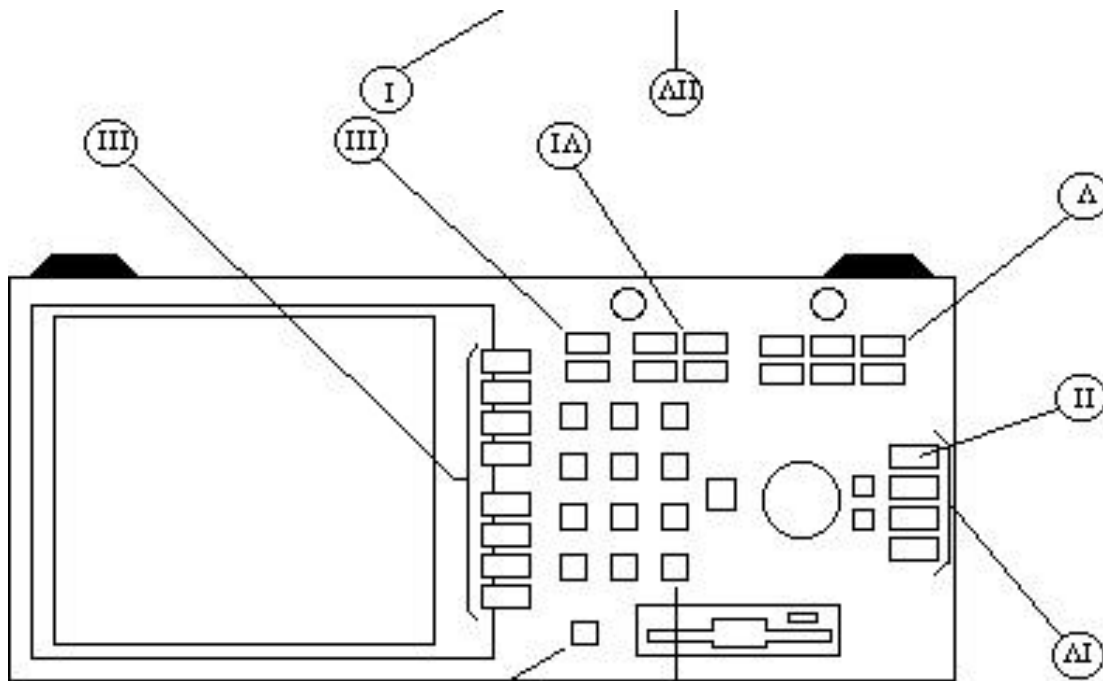

VNA Front panel.

MENU AND FEATURES TOUR

I. The "Begin" Key

- A. Amplifier
 - 1. Transmission
 - 2. Reflection
 - 3. Power

- B. Filter
 - 1. Transmission
 - 2. Reflection
- C. Broadband Passive
 - 1. Transmission
 - 2. Reflection
- D. Mixer
 - 1. Conversion Loss
 - 2. Reflection

After pressing the begin key, you can select from the soft key menu the type of device that you are going to measure. You can then select the type of measurement you wish to make.

NOTE: The amplifier selection adds the measurement power because the user may be interested in the actual power output of the amplifier. The transmission measurement would reflect the amplifiers gain.

NOTE: Conversion Loss is the measurement of relative level of the signal that is converted (down or up) to the desired frequency relative to the level of the signal at the input RF frequency. to the desired output frequency.

II. The "Preset" Key

The preset key resets the Network Analyzer to a known

state, which is given in chapter 14 of the Users Guide.

III. The " Measurement" Section

- | | |
|--|--|
| <ul style="list-style-type: none"> A. Channel One B. Channel Two C. Softkey Menu <ul style="list-style-type: none"> 1. Transmissn 2. Reflection 3. Power 4. Conversion 5. Detection Options 6. Channel Off | <p>After selecting your device under test, you can then make two measurements simultaneously by assigning them to the two measurement channels. Of course the available measurements will depend upon which device you told the Network Analyzer you were measuring.</p> |
|--|--|

IV. The " Source" Section

- | | |
|--|--|
| <ul style="list-style-type: none"> A. Frequency <ul style="list-style-type: none"> 1. Start 2. Stop 3. Center 4. Span 5. CW 6. Display Frequency Resolution B. Sweep <ul style="list-style-type: none"> 1. Sweep Time 2. Sweep Time (Auto/Man) 3. Alt Sweep (On/Off) 4. Frequency Sweep 5. Power Sweep C. Power <ul style="list-style-type: none"> 1. Level 2. RF (On/Off) 3. Start Power D. Menu <ul style="list-style-type: none"> 1. Trigger 2. Number of Points 3. External Reference (On/Off) 4. Spur Avoid Options | <p>You can control the range of the frequency sweep that the Network Analyzer performs by using either the start/stop or center/span options.</p> <p>CW sets the signal source to a single freq.</p> <p>You can specify how long a sweep takes.</p> <p>You can also have the Network Analyzer sweep power.</p> <p>Here you can turn the signal source off, control the output power level, and set a starting power for a power sweep</p> <p>Trigger hold is useful for CW mode.</p> <p>Number of points controls the number of measurements used to create the display graphic, or stored in a disk save operation.</p> |
|--|--|

V. The " Configure" Section

- | | |
|---|--|
| <ul style="list-style-type: none"> A. Scale <ul style="list-style-type: none"> 1. Autoscale 2. Scale/Per Div 3. Reference Level 4. Reference Position 5. Phase Offset 6. Electrical Delay B. Display | <p>The first four selections are similar to their application on an oscilloscope.</p> <p>The last two selections are explained in chapter 10 of the users guide.</p> |
|---|--|

- | | |
|--|---|
| <ul style="list-style-type: none"> 1.Normalize - | <p>The trace is divided by a previous data</p> |
| trace. | |
| <ul style="list-style-type: none"> 2.Data->Mem - | <p>The trace is saved to memory.</p> |
| <ul style="list-style-type: none"> 3.Data - | <p>The trace represents current collected data.</p> |
| <ul style="list-style-type: none"> 4.Memory - | <p>The trace saved to memory is displayed.</p> |
| <ul style="list-style-type: none"> 5.Data/Memory - | <p>Both traces are displayed at once.</p> |
| <ul style="list-style-type: none"> 6.Limit Menu | |
| <ul style="list-style-type: none"> 7.More Display | |
| <ul style="list-style-type: none"> a.Split Disp(Full/Split) | <p>These selections allow you</p> |
| <ul style="list-style-type: none"> b.Title and Clock | <p>to add titles, time stamps,</p> |
| <ul style="list-style-type: none"> c.Y-Axis Label(On/Off) | <p>switch between full and</p> |
| <ul style="list-style-type: none"> d.Y-Axis Lbl (Rel/Abs) | <p>split displays, and turn</p> |
| <ul style="list-style-type: none"> c.Graticule(On/Off) | <p>on/off the display graticule</p> |

C. Cal

- | | |
|---|------------------------------------|
| <ul style="list-style-type: none"> 1.Normalize | |
| <ul style="list-style-type: none"> 2.Transmission | <p>The first three selections</p> |
| <ul style="list-style-type: none"> 3.Reflection | <p>are the most common</p> |
| <ul style="list-style-type: none"> 4.AM Delay | <p>selections and their use is</p> |
| <ul style="list-style-type: none"> 5.Cal Kit | <p>summarized below.</p> |
| <ul style="list-style-type: none"> 6.Detector Zero | |
| <ul style="list-style-type: none"> 7.More Cal | |
| <ul style="list-style-type: none"> a.Velocity Factor | |
| <ul style="list-style-type: none"> b.Smith Chart Zo | |
| <ul style="list-style-type: none"> c.Port Ext's(On/Off) | |
| <ul style="list-style-type: none"> d.Reflection Port Extension | |
| <ul style="list-style-type: none"> e.Trans Port Extension | |

D. Marker

- | | |
|--|--|
| <ul style="list-style-type: none"> 1. 1: | <p>You can place up to eight markers on the</p> |
| <ul style="list-style-type: none"> 2. 2: | <p>display at once. Four of them are found</p> |
| <ul style="list-style-type: none"> 3. 3: | <p>under " More Markers" .</p> |
| <ul style="list-style-type: none"> 4. 4: | |
| <ul style="list-style-type: none"> 5. More Markers | |
| <ul style="list-style-type: none"> 6. Active Marker Off | <p>Use this to turn off specific markers.</p> |
| <ul style="list-style-type: none"> 7.All Off | <p>Turn off all the markers.</p> |
| <ul style="list-style-type: none"> 8.Marker Functions | <p>(Marker to Center,Marker to Reference,etc.)</p> |
| <ul style="list-style-type: none"> 9.Marker Search | |

E. Format

- | | |
|---|--|
| <ul style="list-style-type: none"> 1.Log Mag | <p>These represent the different display</p> |
| <ul style="list-style-type: none"> 2.Lin Mag | <p>formats. Their significance will become</p> |
| <ul style="list-style-type: none"> 3.SWR | <p>more clear as you progress through the lab.</p> |
| <ul style="list-style-type: none"> 4.Delay | |
| <ul style="list-style-type: none"> 5.Phase | |
| <ul style="list-style-type: none"> 6.Smith Chart | |
| <ul style="list-style-type: none"> 7.More Format | |
| <ul style="list-style-type: none"> a.Polar | |
| <ul style="list-style-type: none"> b.Real | |
| <ul style="list-style-type: none"> c.Imaginary | |
| <ul style="list-style-type: none"> d.Impedance Magnitude | |

F. Average

1. Average(On/Off)
2. Restart Average
3. Average Factor
4. System Bandwidth
5. Delay Aperture

Note: These can be used to deal with noisy measurements.

VI. The " System" Section

A. Save Recall

1. Save State
2. Re-Save State
3. Define Save
4. Recall Save
5. Select Disk
6. File Utilities
7. FastRecall(On/Off)

The first section will allow you to save data to a disk. For this information look in the User's Guide

B. Hard Copy

1. Start
2. Abort
3. Select Copy Port
4. Define Printer
5. Define Plotter
6. Define Hardcopy

If a plotter or printer is connected to either the RS-232 or HP-IB port, you can plot data from the screen.

C. System Options

1. HP-IB
2. System Config
3. Operating Parameters
4. Service

Look in the System Configuration section to see how the Network Analyzer is configure.

D. Preset (See Previous Section)

VII. The " Entry" Section

- A. Numeric Keypad
- B. Knob and Up/Down Arrows

Whenever alphanumeric input is required, you use this section

CALIBRATION PROCEDURES

When measuring a DUT, you will essentially be collecting S-parameter information for a 2 port network. S11 relates to the reflected energy from port, and S12 relates to the energy transmitted through to port two. The Vector Network Analyzer is also capable of measuring the phase angle of the reflected or transmitted wave which may be due either to delay or reactance. In order that the data collected represents the response of the device under test only, and not parts related to the cables, connectors, and the Network Analyzer itself, it is necessary to perform calibrations of the equipment.

I. Reflection

The DUT will represent a load to the Network Analyzer. To be able to judge just what type of load the DUT is, it will be necessary to connect termination's which are "known". For this network analyzer these terminations will be a short, an open, and a matched load. Based on these terminations the network analyzer applies the data it collects to a an error model. It will calculate error coefficients which will be applied to raw measurement data, to remove from that data the parts that are associated with thing you don't want to measure, again cables, connectors, and the network analyzer.

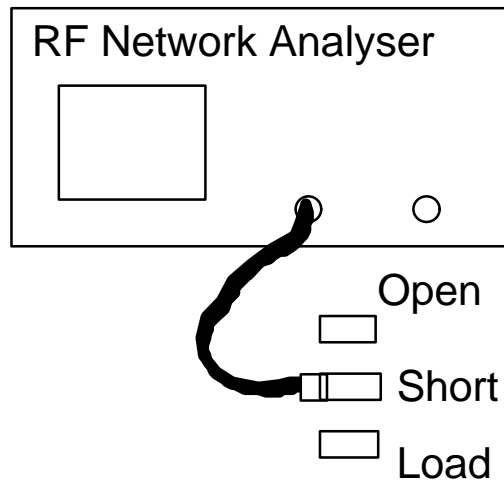

The procedure for reflection calibration is as follows:

1. Press the " Cal" Button when you are assured that the channel you want to calibrate for has been set to measure reflection, by pressing the appropriate channel button and selecting reflection from the softkey menu.
2. Press the " reflection" softkey.
3. Select " One Port" softkey.
4. At this point the HP 8714 will direct you. You will do the following:

- a. provide the terminations the vector analyzer asks for.
- b. try not to move the cable much, and try to ensure that the cable is in the same position for each cal measurement.
- c. Ensure that all connectors remain sufficiently tight, but not over tight.

II. Transmission

Consider the illustration below:

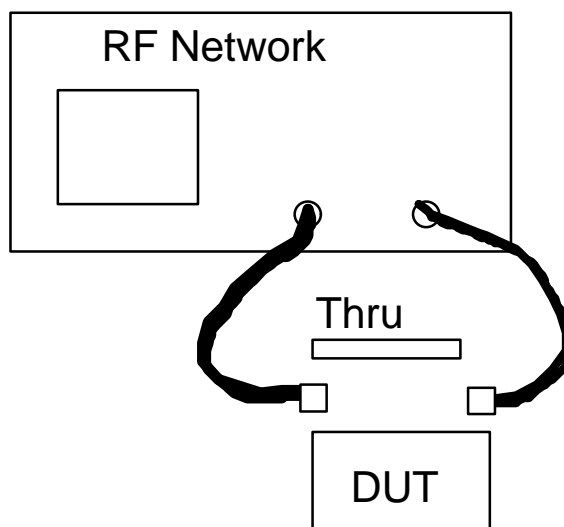

The HP8714 can measure the power received at the RF in port and compare that value to the power sent at port one. However if the Network Analyzer has some frequency variation, it will be necessary to measure this frequency dependent loss to that it is compensated for. This will allow the Network Analyzer to show the frequency response due to the DUT only. Also, it is possible for energy to make its way from the output port to the RF in port by some way other than the through cable. This is referred to as crosstalk, and a calibration to account for this is necessary when the dynamic range of the measurements to be taken is relatively large.

A. Transmission Only

1. Select the channel you wish to do the transmission calibration for. Ensure that it is set to "transmission"
2. Press the CAL button and select Transmission from the softkey menu.
3. You are then presented with three options in the softkey menu.
 - a. Restore Defaults
 - b. Response
 - c. Response and Isolation

4. Choose b.
5. The network analyzer will direct you to connect a through line to the RF out port and the RF in port.
6. Press measure standard.

B. Response and Isolation

1. Same as above procedure until step four. Choose option c.
2. The network analyzer will direct you to connect 50 Ohm loads to both the RF out and RF in ports.
3. Press the "measure standard" softkey
4. The network analyzer will direct you to connect the through cable.
5. Press the "measure standard" softkey

III. Normalization

The normalization calibration is the simplest of these three calibrations. This calibration collects the data from a thru line measurement, and divides the subsequent DUT measurements with this data. If any frequency settings are changed, the calibration will be invalidated. The procedure for the normalization calibration is given here:

1. Setup the analyzer for your measurement:
 - a. Select the type of measurement: (Reflection, Transmission, etc.)
 - b. Enter operating parameters other than the default
2. Connect your equipment to a short(reflection) or a thru (transmission or conversion loss).
3. Press the CAL button and the Normalize softkey.
4. After the calibration "/M" is shown at the top of the display to remind you that the data you are looking at is being divided by the measured thru data.